

⚠️ IMPORTANT

READ BEFORE YOU BEGIN INSTALLATION

IT IS CRITICAL FOR YOUR SAFETY THAT YOU CAREFULLY READ AND FOLLOW THE SAFETY CAUTIONS AND INSTALLATION INSTRUCTIONS BOTH PRIOR TO AND DURING INSTALLATION.

USER SAFETY CAUTION

During installation, be mindful of the potential for sharp edges on the product or vehicle. Taking proper safety precautions helps ensure a safe and smooth installation process.



Always wear protective gloves and handle components with care to reduce the risk of injury.

TEMPERATURE SURFACE CAUTION

During high temperatures or extended sun exposure, surfaces of this product may become hot to the touch, posing a risk of burns or injury. Use caution when handling the product in hot weather and allow time for it to cool before contact.



Always check surface temperature before use to ensure safe handling conditions.

FASTENER TORQUE CAUTION

All fasteners must be tightened to the specified torque values provided in the installation instructions to ensure proper fit and safe operation of the tonneau cover. Under- or over-tightening can lead to product failure, potential damage to your vehicle, injury, or safety hazards while driving.

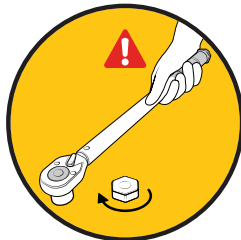

Always use a calibrated torque wrench and follow the specifications in the installation instructions.

PINCH POINT SAFETY CAUTION

This tonneau cover may create pinch points when closing or operating near solid surfaces such as the truck bed rails or tailgate. To prevent injury, keep hands, fingers, and other body parts clear of moving parts during operation.



Always operate the cover slowly and with caution to ensure safe and proper use.

! IMPORTANT

READ BEFORE YOU BEGIN INSTALLATION

IT IS CRITICAL FOR YOUR SAFETY THAT YOU CAREFULLY READ AND FOLLOW THE SAFETY CAUTIONS AND INSTALLATION INSTRUCTIONS BOTH PRIOR TO AND DURING INSTALLATION.

ENTRAPMENT SAFETY WARNING

This tonneau cover does not feature a manual release mechanism from inside the truck bed. To prevent the risk of entrapment, never allow anyone to be inside the bed of the truck when the cover is closed.

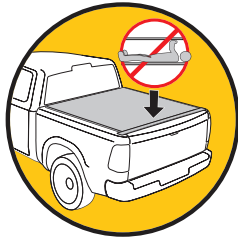

Always ensure the area is clear before closing the cover, and keep the cover securely latched when not in use to avoid accidental closure.

COVER ATTACHMENT WARNING

A partially folded up or unsecured cover may detach during transit, risking vehicle or property damage and personal injury.



Always verify the tonneau cover is properly secured before operating the vehicle.

CARGO TRANSPORT WARNING

When transporting cargo that is taller than the truck bed, the cover must be fully folded open and securely fastened with both retainer straps. An unsecured cover can detach while driving, risking vehicle or property damage and personal injury.

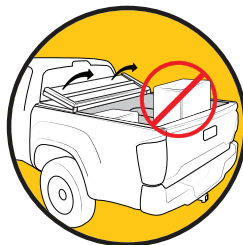

Never operate the vehicle with a partially folded up cover.

COVER POSITION WARNING

Before operating the vehicle, always verify the tonneau cover is either fully folded open and secured with both buckles or fully folded closed and securely latched down.

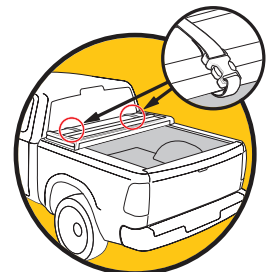

Never operate the vehicle if the tonneau cover is not properly secured.

NOTE: It is important that all the areas where the bed cover mounts to the truck are clean and free of debris before installation.

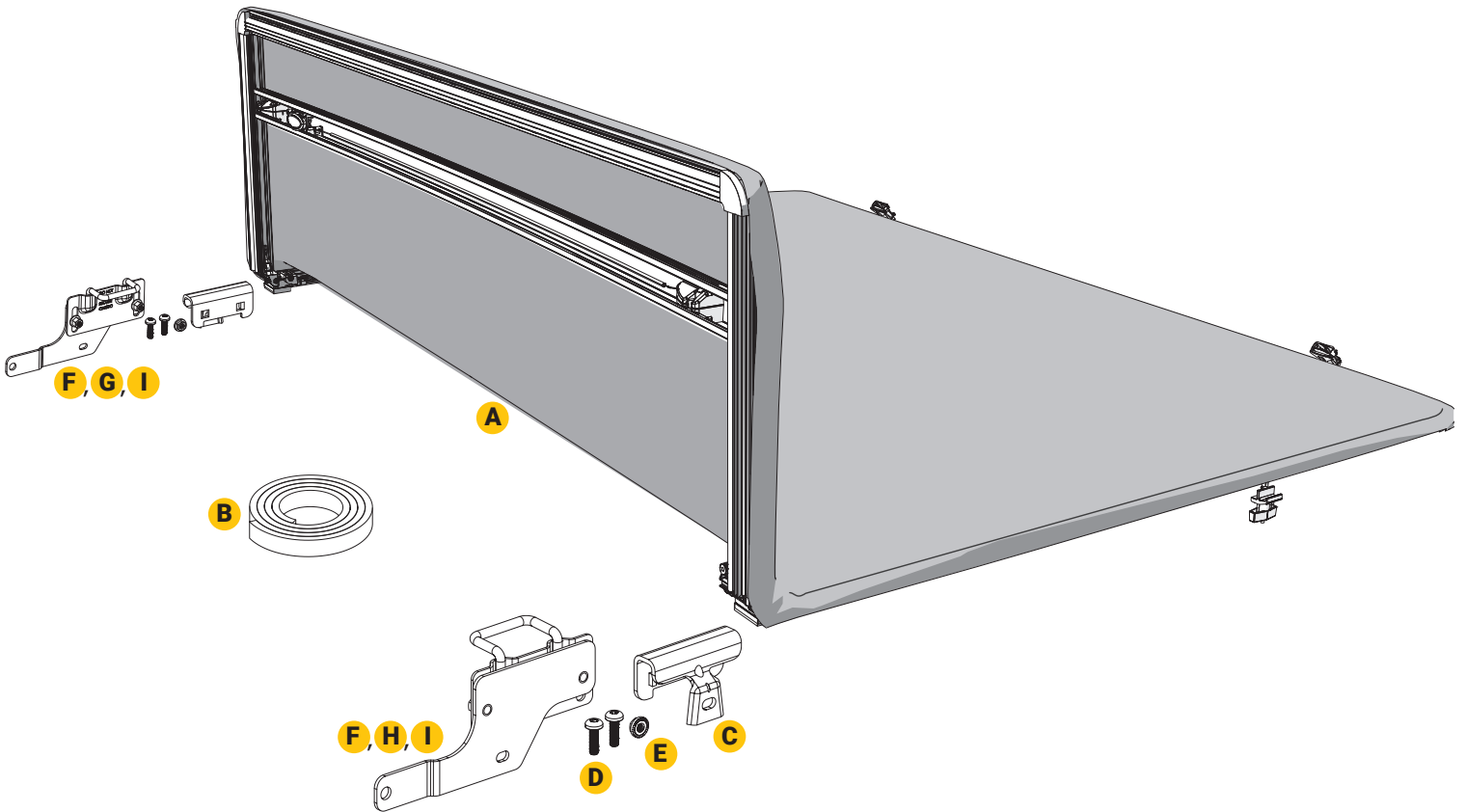

PARTS INCLUDED IN YOUR KIT

- A** 1x Cover assembly
- B** 1x Bulkhead seal
- C** 2x Cab brackets
- D** 4x T-30 Torx bolt
- E** 2x M6 Flange nuts
- F** 2x Striker brackets
- G** 1x Driver tail latch bracket
- H** 1x Passenger tail latch bracket
- I** 4x Lock nuts (On latch brackets)

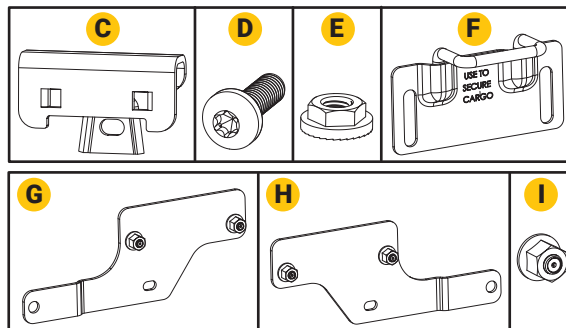

Components F,G,I come pre-assembled and F,H,I come pre-assembled

TOOLS PROVIDED

- Torx wrench - T-20
- Torx wrench - T-27
- Hex wrench - 2.5mm

TOOLS REQUIRED

- T-30 Torx driver
- 10mm Socket or wrench
- Isopropyl alcohol
- T-45 Torx driver



- 1** Install the bulkhead seal. Clean the top of the bulkhead where the seal will go with soap and water to remove dirt and debris. Then clean the same area with isopropyl alcohol to remove wax or grease and to evaporate any remaining water. Allow the surface to dry. The seal should be placed flush with the front edge of the bulkhead and should be snug between the truck bed rails. Peel the backing paper from the bulkhead seal (B) and apply pressure to the entire seal to make sure that the adhesion is good.

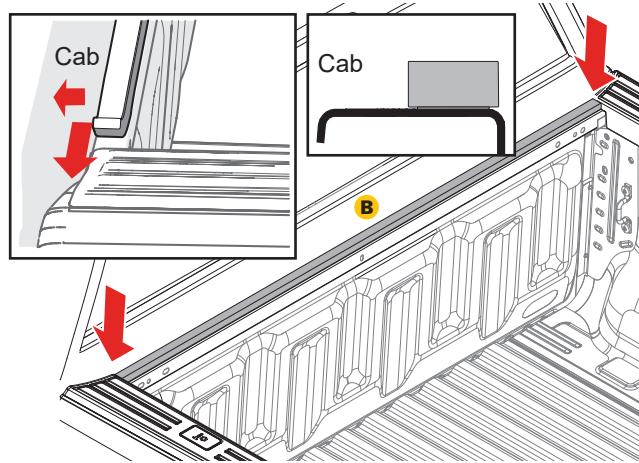

- 2** Remove the two corner plastic clips from the passenger and driver side bed caps as shown below. Pry out the center first, then pry out the entire clip. These will not be used again unless you permanently remove the bed cover assembly. Store clips in a plastic bag and put them in your glove box of vehicle.

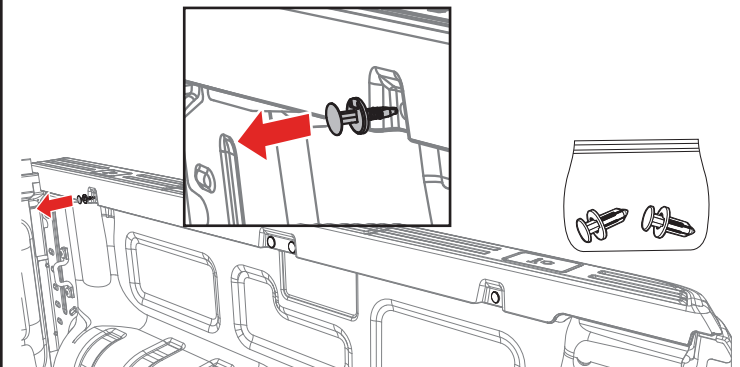

- 3** Install the brackets (C), bolts (D) and nuts (E) provided using the T-30 tool on the passenger and driver side bed caps, where you removed the two corner clips in Step 1. Make sure the nut is behind the sheet metal, as shown below. **NOTE:** Torque to 8 ft/lbs (11 Nm). 

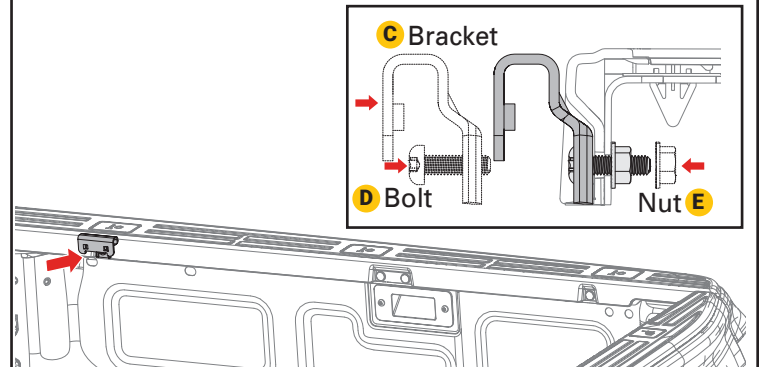

- 4** Remove the T-45 Torx screw from the tailgate slam bumper. **Do not discard screw.** Repeat on the opposite side of the truck bed.

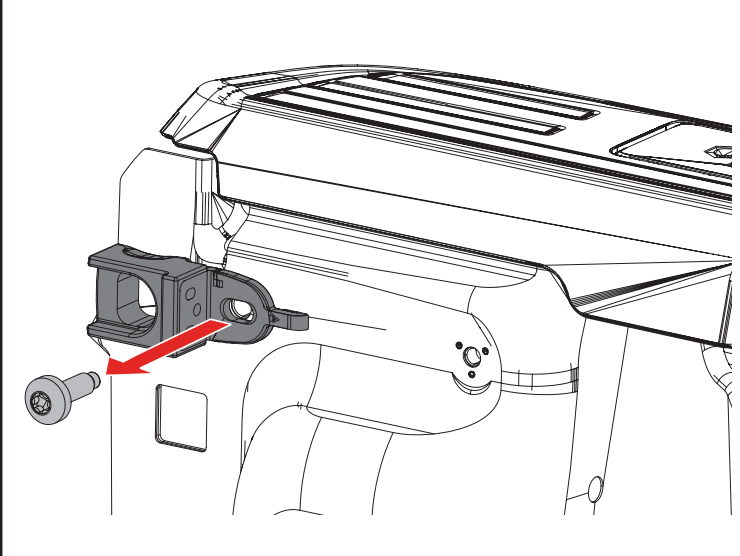

- 5** The brackets are assemblies comprised of the striker bracket (F) and a driver tail latch bracket (G). Align the two holes in the driver tail latch bracket (G) with the tailgate slam bumper hole you removed the Torx screw from in step 8 and the other hole in the side of the bed as shown. Repeat on the opposite side of the truck bed with striker bracket (F) and passenger tail latch bracket (H).

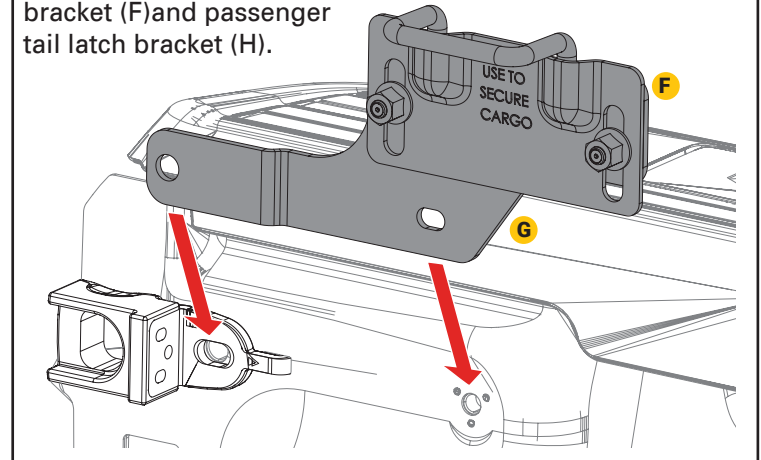

6 Re-install one of the T-45 Torx screws from step 8 through the bracket (G) and into the same hole you removed it from. Then install one of the provided T-30 Torx bolts (D) into the other hole in the same bracket and into the hole in the side of the bed. Loosely fasten the screws. Repeat on the opposite side of the truck bed.

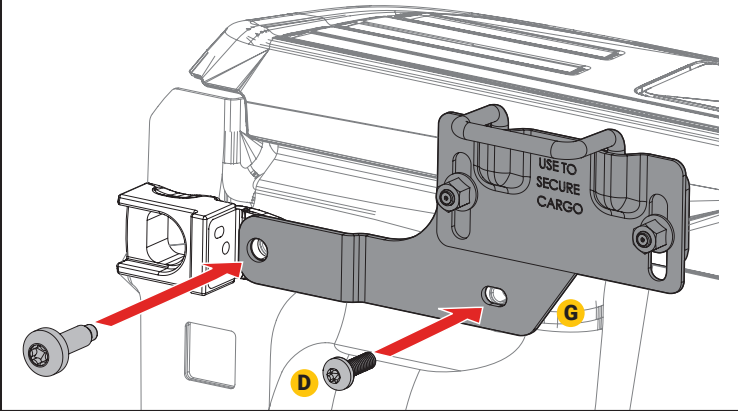

7 Tighten the Torx screw removed in step 4 using a T-45 Torx bit and torque to 16ft-lbs (22Nm) & using a T-30 Torx bit and torque bolt (D) to 8ft-lbs (11Nm).  Repeat on the opposite side of the truck bed.

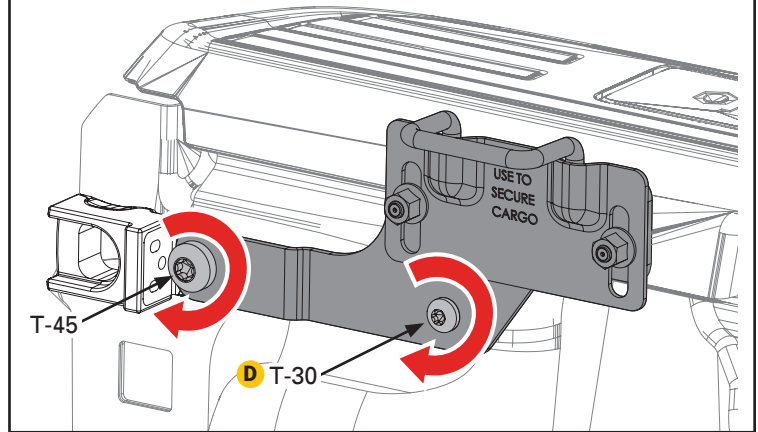

8 Place the folded, assembled bed cover (A) over the cab end of the truck box.

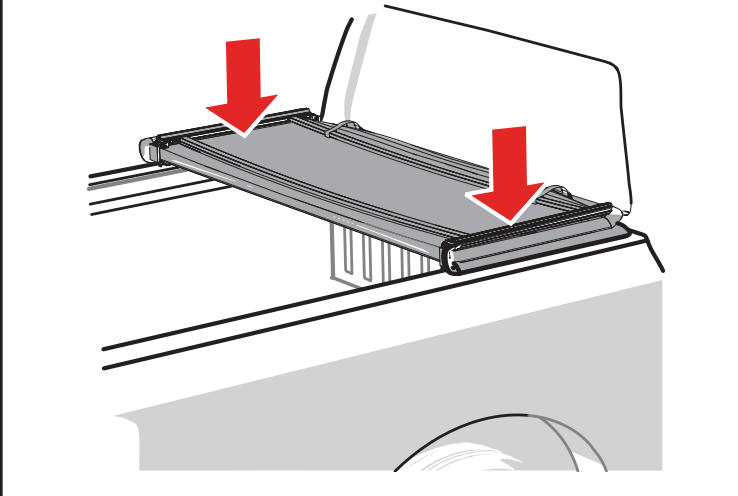

9 Unfold the bed cover (A) fully and adjust position over the truck bed for proper front (cab) and rear (tailgate) alignment. When positioned front and back, the tailgate seal should contact the tailgate as shown in step 10.

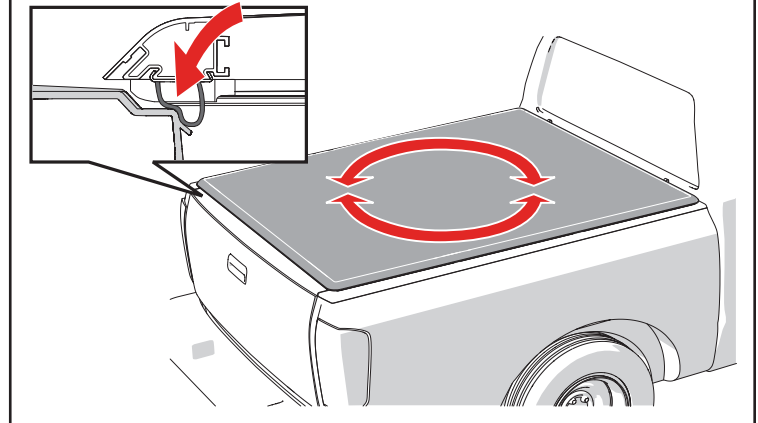

10 **PROPER POSITION OF TONNEAU COVER.** Close the tailgate and unfold the cover. Check that the cover is parallel and square with the truck bed and bed rails. Adjust the cover until the bulb seal fits with the tailgate as shown. If not parallel or square, open the cover and loosen the cab clamps to reposition the cover. If the cover is too far back the tailgate will not close.

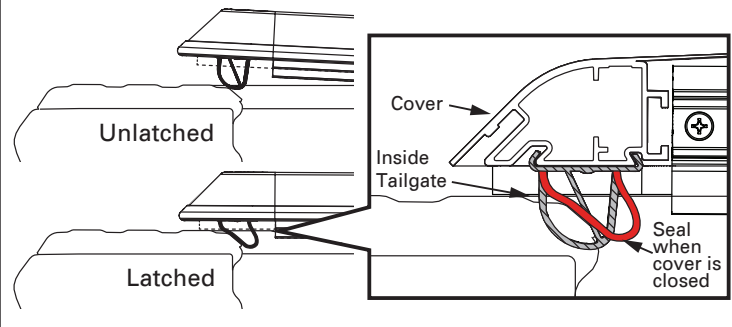

11 Carefully refold the bed cover (A) without shifting its position on the truck bed.

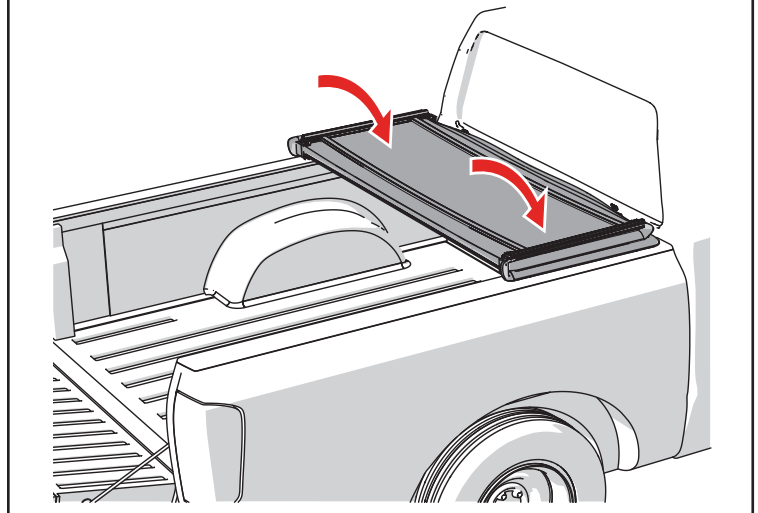

12 Hook the cab clamp under the installed cab rail brackets (C). **NOTICE:** Do not secure to the plastic bed rail or bed cap. The clamp must contact the metal bracket. Ensure that the clamp is positioned under the metal bracket and hand tighten until the jaw makes contact, then tighten an additional two turns. **NOTICE: DO NOT** use a wrench or over tighten. Repeat on the opposite side of the truck bed. 

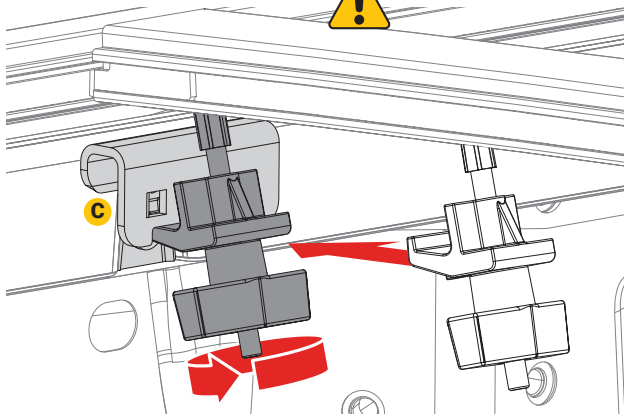

13 The tethers come installed looped over the bed cover bow with a clamp at the other end. Attach the hook/tether to the front tie-downs on both the driver and passenger side. 

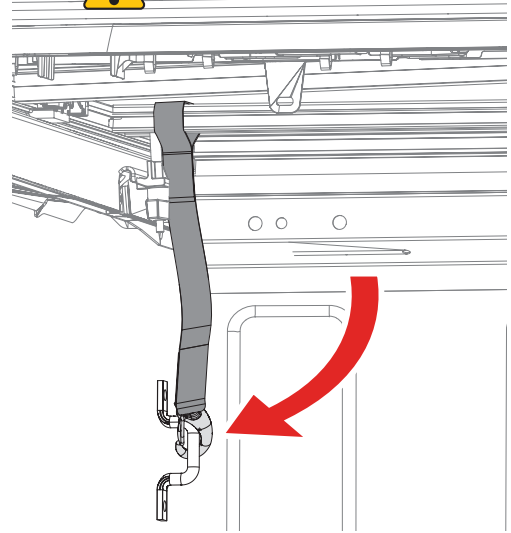

14 With the tailgate open and the front (cab) clamps secure, completely close the bed cover. 

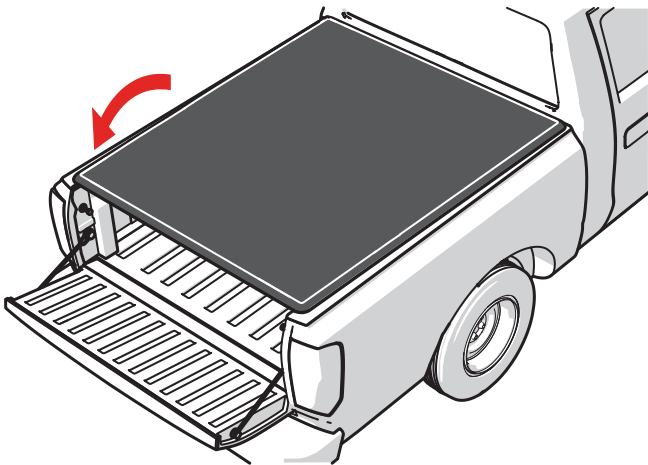

15 Align the latch with the striker bracket (F). Push down on the bed cover while tightening the lock nuts (I), (10mm) to 8ft-lbs (11Nm) with 10mm socket or wrench. Ensure that the nuts are tightened on each side of the truck. 

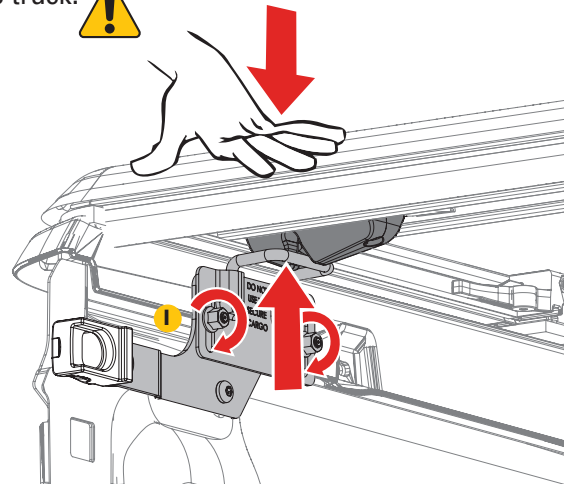

16 Adjustments and tightening of the latch assembly is required.

The bed cover latch assemblies and rotary knob come from the factory only partially tightened to allow for installation adjustments. Both latches and rotary knob will require adjustment and final tightening. **Only use the hand tools provided, do not use power tools.**

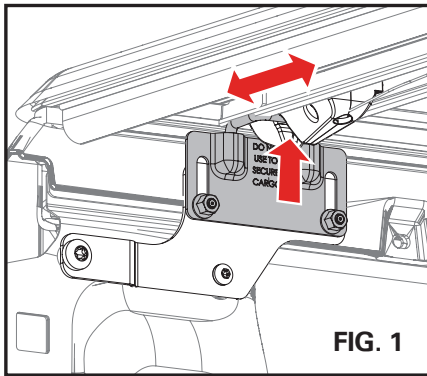

Lower the rear of the bed cover and adjust the position of each latch so that they engage with the striker brackets, (Fig. 1). With the latches adjusted, from underneath the cover, use the provided T-20 Torx wrench to tighten the two screws, (Fig. 2) in both the driver and passenger side latches.

The cable from the driver's side latch comes routed through the barrel clamp of the actuator and hangs out. Slide the actuator so that 3/4" - 1" (19.1 - 25.4mm) of cable extends through the barrel clamp, (Fig. 3).

Rotate the actuator knob until you see the flat head screws. Tighten the two flat head screws using the provided T20 hex wrench, (Fig. 3).

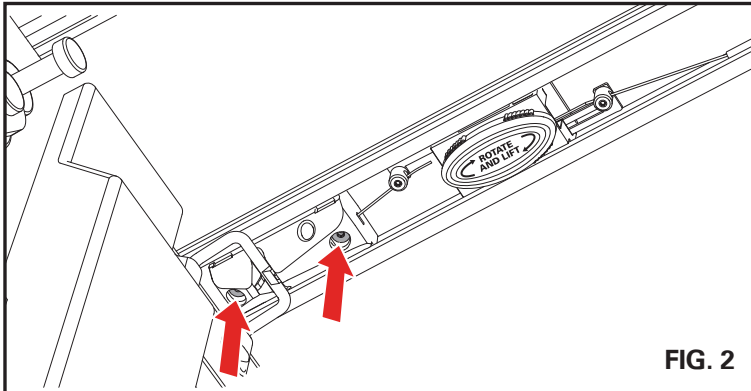

The cable from the passenger side latch comes routed through the other barrel clamp of the actuator. Excess cable length is routed through the middle of the actuator assembly (above the bottom plate below the plastic housing). Do not trim the excess cable, leave it for future adjustments, (Fig. 3).

Next, tighten the barrel clamps, (Fig. 4) with the provided 2.5mm hex key to secure the latch cables. Rotate the actuator knob, (Fig. 4) to verify that the latches disengage from the striker brackets.

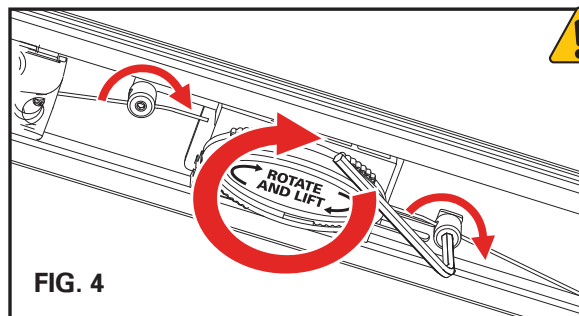
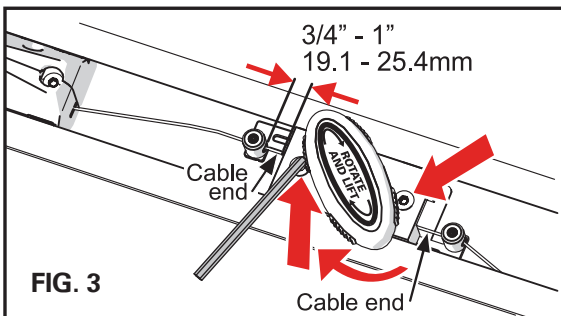

Double-check that the cover is secure and tight to the truck bed by gently lifting the corners to ensure the mechanisms are engaged.

17 To make the final adjustment, loosen the striker bracket nuts. Then move the striker bracket (F) down by firmly pushing the cover (A) or pulling the rear bow downward to the truck rail and tailgate. Push down on the bed cover while tightening the lock nuts (I), (10mm) to 8ft-lbs (11Nm) with 10mm socket or wrench. Make sure that both sides match, then retighten the screws. 

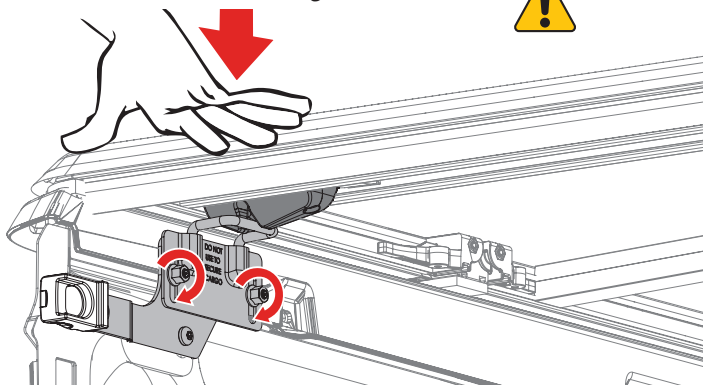

Opening the cover
Open the cover by twisting the actuator knob and lifting the cover.

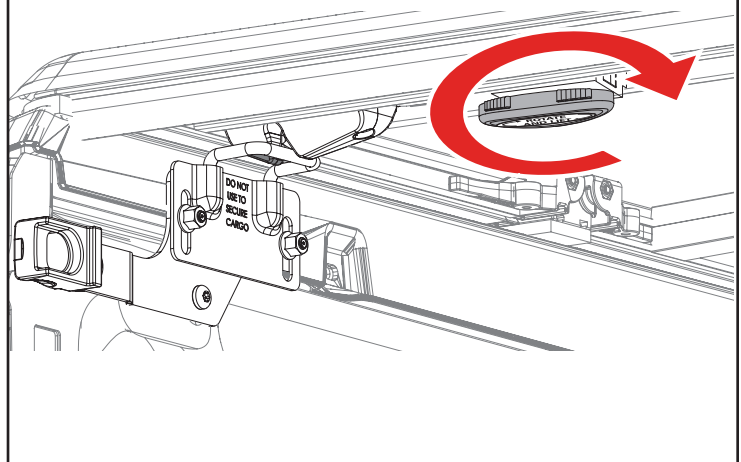

Securing the cover

To drive with the cover open, fold the cover forward to the cab and fasten BOTH straps in the middle section to the front rail. Check that the straps are tight, and pull the strap end if too loose.

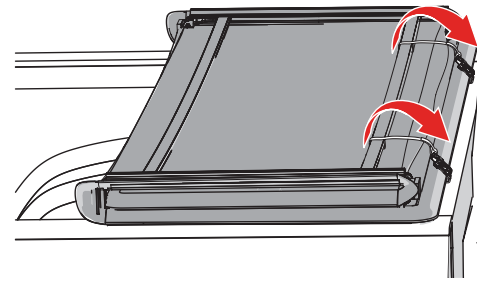
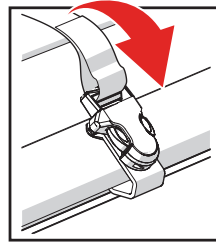

IMPORTANT

Re-tighten the front/cab clamps and tethers after the first week of driving the vehicle. Also periodically check the clamps and tethers to ensure they are secure.

Closed/Extended Position – Bed cover must be completely secured by all four (4) clamps.

Open/Folded Position – Bed cover must be completely folded up (all panels) and secured at the cab with the provided buckles straps and with both tethers attached.

Do NOT drive with the bed cover in a partially open position.

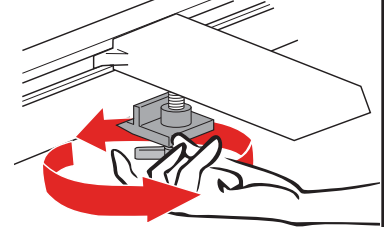

Do NOT allow the vehicle to be towed backwards without first removing the cover from the vehicle.



Remove any snow or foreign matter before folding the bed cover.

REPLACEMENT PARTS

Replacement parts can be ordered online at extang.com/replacement-parts or you can contact our Customer Service Department for assistance. When ordering, xxx represents the 3 digit suffix, as referenced on the sales receipt or vehicle application list.

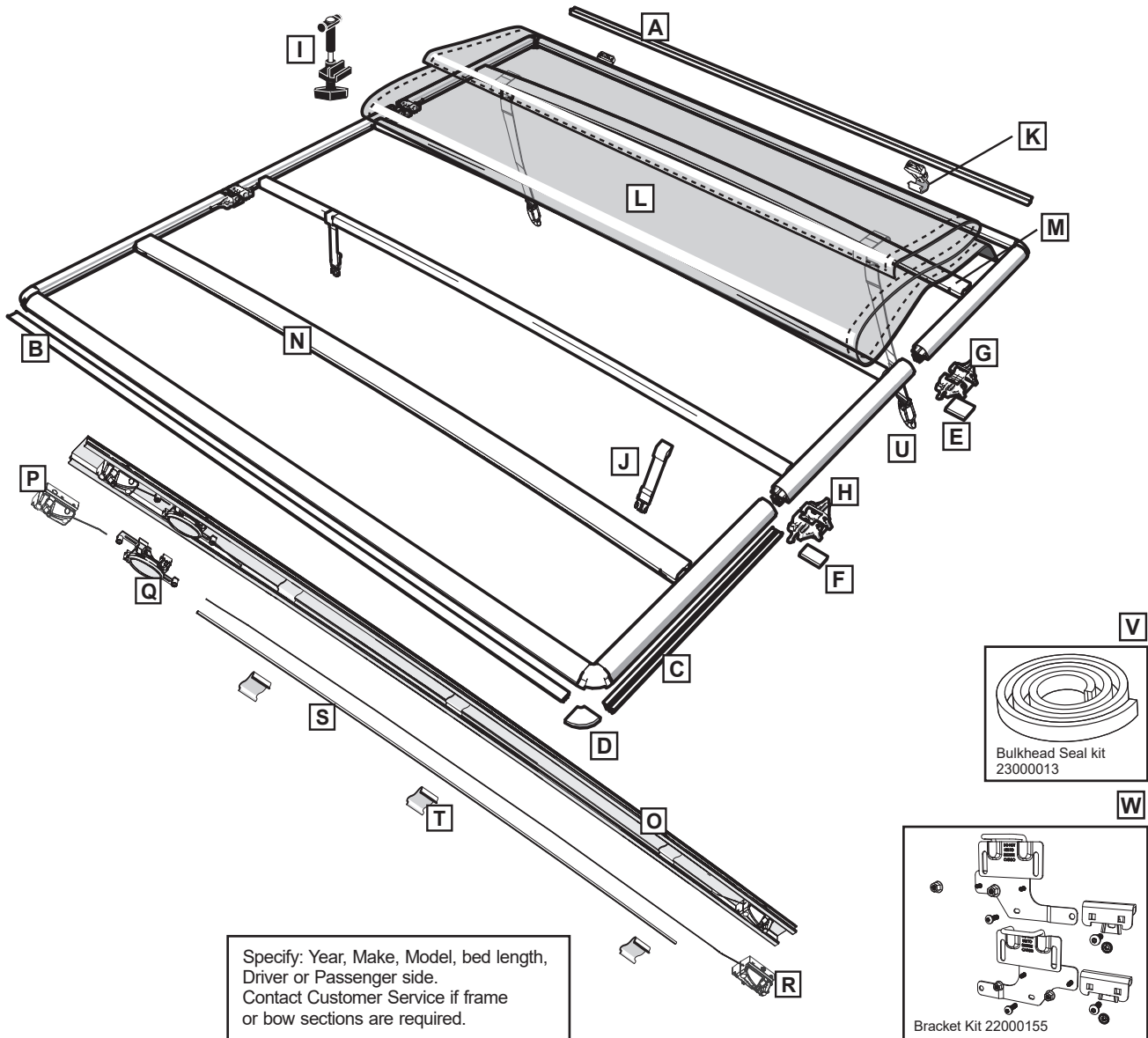

Call Out	Title	Part Number	Description	Qty
A	Cab Seal	32002112	Single length seal (6'), hollow seal, cut to fit	1
B	Tailgate Seal	32000118	Single length seal, (68"), 4-fin, cut to fit - 2026 Ranger	1
C	Side Rail Seal	32560368	Single length (68") Side Seal, one length will fit two panel sides, cut to fit, (there are 6 sides per cover). Two seals for 6' beds, three for longer beds.	1
D	Corner Seal	32440100	Measure for thickness- 0.375", 0.5", 0.75"	1
E	Hinge Seal, Cab	32920104	Seal only	1
F	Hinge Seal, Tail	32920102	Seal only	1
G	Cab Hinge	31442015	Seal not included, see item Hinge Seal, Cab (E)	1
H	Tail Hinge	31442005	Seal not included, see item Hinge Seal, Tail (F)	1
I	Cab Clamp	1034	Single clamp for the front/cab end	1
J	Tie Down Strap	54440400	Tie Down Strap (Short), with Male Buckle-fits 4 bow bed cover systems	1
K	Tie Down Strap	54720400	Tie Down Strap (Long), with Male Buckle-fits 3 bow bed cover systems	1
L	Buckle Assembly	31920120	Single Buckle assembly, w/Female Buckle, Front/cab end	1
M	Tarp	90638-20	Vinyl tarp only, ALX vinyl, call Customer Service to order	1
N	Cab Bow	90xxx-10	Disassembly and reassembly of the cover is required, call Customer Service to order	1
O	Tail Bow	90xxx-14	Disassembly and reassembly of the cover is required, call Customer Service to order	1
P	Bow Assembly	90638-67	Complete assembly including Latches, Actuator Assembly, cable/conduit, clips with a Rear Bow, call Customer Service to order	1
Q	Latch Assembly	28900100	Assembly for driver side	1
R	Actuator	28900102	Latch actuator assembly	1
S	Latch Assembly	28900101	Assembly for passenger side	1
T	Cable Conduit	31920003	Latch cable cover conduit only. Trimming length may be necessary.	1
U	Conduit Clips	35920202	Latch cable conduit clips	3
V	Tether Kit	22000028	Tether kit including 2 tether straps and 2 hookS - 2026 Ranger	1
W	Bulkhead Seal Kit	23000013	Seal only - 2026 Ranger	1
X	Bracket Kit Front & Back	22000155	Bracket Kit - 2026 Ranger	1

LIMITED LIFETIME WARRANTY

The cover, including as applicable any hardware kit (e.g., rails, clamps, and bows) and fabric, carries a limited lifetime warranty. This limited warranty is subject to the following terms:

WARRANTY COVERAGE

This tonneau cover is warranted against defects in materials or workmanship. This warranty is void if the product has been damaged in an accident, or due to neglect, unforeseeable use, improper installation, improper servicing, or other cause not arising out of defects in material or workmanship.

WARRANTY IS NOT TRANSFERABLE

The warranty is to the initial owner purchasing the tonneau cover and it is not transferrable to a subsequent end user. Proof of purchase may be required to enforce the warranty rights.

WARRANTY CONDITIONS

Failure to follow these warnings and care instructions will void the warranty:

- Clean with mild automotive soap and water only.
- Do not use conditioners that contain silicone or petroleum.
- Tonneau cover must be secured at all points when vehicle is in motion. When not fully extended, cover must be completely folded up and secured at the cab with the provided buckle straps and tethers attached. Do NOT drive with the bed cover in a partially open position..
- Check front/cab clamps and retention mechanisms for tightness after a week of driving following installation (or re-installation) of the cover and periodically thereafter.
- Before opening, cover must be free of all foreign materials including snow and ice.
- To avoid potential damage to the cover, panel clamps/latches must be in their stored positions prior to opening/folding the panel.
- Do NOT tow your vehicle from the rear with the cover on your vehicle. If towing from the rear is required, the cover MUST be removed from the vehicle and properly stored.

WARRANTY PERFORMANCE

If all warranty conditions are met, a defective tonneau cover, tarp, or hardware component will either be repaired or replaced (at our option). We reserve the right, for any warranted return, to substitute a newer model of tonneau cover having similar form and function, to offer a warranty discount on an entire replacement system, and/or provide remedies other than those mentioned in this document.

WARRANTY PROCESS

A Return Authorization number must be obtained from our Customer Service Department prior to returning any product. We may require the original item to be returned postage prepaid for final determination. Shipping charges will apply for any repair or replacement. Other than postage or shipping charges, no charge will be made for repair or replacement under this warranty.

This warranty gives you specific legal rights. As an owner, you may also have additional rights and remedies under the laws of your state.

WARRANTY REGISTRATION

Warranty registration must be on file and/or proof of original purchase (detailed and dated receipt) required for warranty to be effective.

Register online at <https://realtruck.com/extang-warranty>

**REGISTER
YOUR
WARRANTY
ONLINE**



SOMETHING DAMAGED? MISSING PARTS?

CALL US FIRST
800-877-2588

WE CAN HELP YOU QUICKLY AND EASILY OVER THE PHONE

Experienced Customer Service staff are available
to answer all your truck bed cover questions

CUSTOMER SERVICE HOURS

8:30 a.m. TO 6:00 p.m. EST, MONDAY - FRIDAY

Truck bed cover model: _____

Purchase date: _____

Lot code: _____

Lot code can be found on the underside of cover.