

## FRFLX

## FORD

Rear suspension package  
Ensemble pour suspension arrière  
Ensemble para suspensión de trasero  
INSTRUCCIONES DE INSTALACIÓN

## INSTALLATION INSTRUCTIONS

- Carefully read and understand all instructions prior to installation. Professional installation required.
- Working on one side of vehicle at a time, raise vehicle allowing suspension to hang freely.
- Remove and retain OEM inner bolt #1 M14 X 90.

**NOTE:** DO NOT REMOVE BOLT #2.

Removing both bolts may result in loss of upper control arm positioning allowing compressed coil spring to release position.

- Install Timbren frame bracket #3 using OEM bolt #1. Leave bolt #1 loose approx 1 turn. Non-permanent threadlocker adhesive such as Loctite 242 must be applied.
- Remove and retain OEM outer bolt #2 M14 x 90.
- Rotate Timbren bracket #3 aligning holes with OEM.
- Install OEM bolt #2. Non-permanent threadlocker adhesive such as Loctite 242 must be applied.
- Torque both OEM bolts 111 lb-ft in accordance with OEM specifications.
- Mount Aeon rubber spring using Timbren supplied fasteners.

**NOTE:** These instructions are not intended to replace OEM guidelines for safe removal and replacement of OEM fasteners.

Follow OEM guidelines ensuring a nonpermanent threadlocker such as Loctite 242 used when replacing OEM bolts.

Secure OEM bolts to 111 lb-ft in accordance with OEM specifications.

Do not exceed vehicle manufacturer's recommended axle weight rating. Check for AEON® interference with vehicle components - Under load AEON® will "expand" in diameter.

## INSTRUCTIONS DE MONTAGE

- Veillez lire et comprendre toutes les instructions avant de procéder à l'installation.
- Travailler sur un côté du véhicule à la fois. Monter le véhicule pour permettre à la suspension de pendre librement.
- Retirer et conserver le boulon intérieur du fabricant d'origine #1 M14 x 90.

**REMARQUES:** NE PAS ENLEVER LE BOULON #2. Le retrait des deux boulons peut entraîner la perte du positionnement du bras de suspension supérieur permettant au ressort hélicoïdal comprimé de relâcher sa position.

- Installez le support du cadre #3 de Timbren en utilisant le boulon d'origine #1. Laissez le boulon #1 desserré d'un tour. Une colle adhésive non permanente telles que Loctite 242 doit être appliqué sur le filetage.
- Retirer et conserver le boulon extérieur #2 d'origine M14 x 90.
- Tourner le support Timbren #3 en alignant les trous avec ceux du fabricant.
- Installez le boulon d'origine #2. Une colle adhésive non permanente telles que Loctite 242 doit être appliqué sur le filetage.
- Serrer les deux boulons d'origine avec un couple de 111 lb-pi, conformément aux spécifications du fabricant.
- Monter le ressort en caoutchouc Aeon en utilisant la boulonnerie fournie avec l'assemblage Timbren.

**REMARQUES:** Ces instructions ne sont pas destinés à remplacer les lignes directrices du fabricant pour le retrait et le remplacement des attaches d'origine.

Suivez les directives du fabricant en cas de remplacement d'un boulon d'origine en assurant l'utilisation d'une colle adhésive non permanente telles que Loctite 242.

Serrer les boulons d'origine à 111 lb-pi, conformément aux spécifications du fabricant.

Ne pas dépasser le poids nominal sur l'essieu recommandé par le fabricant du véhicule. Vérifier que le ressort AEON® n'a pas d'incidence sur d'autres pièces du véhicule - Le ressort AEON® augmentera son diamètre avec la charge.

- Por favor, lea y comprenda todas las instrucciones antes de la instalación.
- Trabajo en un lado del vehículo en el momento. Montar el vehículo para permitir que la suspensión para colgar libremente.
- Retire y conserve el perno interior del fabricante original #1 M14 x 90.

**NOTA:** NO RETIRE EL PERNO #2. La remoción de los dos pernos puede provocar la pérdida de la posición del brazo de suspensión superior que permite que el muelle en espiral superior comprimido para cambiar su posición.

- Instale el soporte de chasis Timbren #3 con el tornillo original #1. Deja el perno desenroscar #1 de 1 vuelta. Un pegamento adhesivo no permanentes, tales como Loctite 242 debe aplicarse a las roscas.
- Retire y conserve el tornillo #2 de origen M14 x 90.
- A su vez el apoyo Timbren #3, alineando los agujeros con los del fabricante.
- Instale el perno de origen #2. Nota: Un pegamento adhesivo no permanentes, tales como Loctite 242 debe aplicarse a las roscas.
- Apriete los dos pernos originales con esfuerzo de torsión de 111 lb-pie, según lo especificado por el fabricante.
- Monte el resorte de caucho Aeon utilizando los elementos de sujeción Timbren provistos.

**NOTA:** Estas declaraciones no están destinadas a sustituir las directrices del fabricante para el retiro y sustitución de elementos de sujeción.

Siga las instrucciones del fabricante para el reemplazo de un perno de garantizar el uso de un pegamento adhesivo no permanentes, tales como Loctite 242.

Apriete los pernos de origen de 111 lb-pie, de conformidad con las especificaciones del fabricante.

No exceda la carga nominal en el eje recomendada por el fabricante del vehículo. Compruebe que no haya interferencia entre el resorte AEON® y los otros componentes del vehículo. Bajo carga, el resorte AEON® se amplía en diámetro.

Ref. = Reference = No. de référence = Núm. de referencia  
Part = Part #. = No. de pièce = Núm. de pieza  
Qty. = Quantity = Quantité = Cantidad

Ref	Part	Qty
1	OEM INNER BOLT	2
2	OEM OUTER BOLT	2
3	K10501-003	2
4	A1610A-003	2
5	A00515-65P30	2
6	F11538-350	2

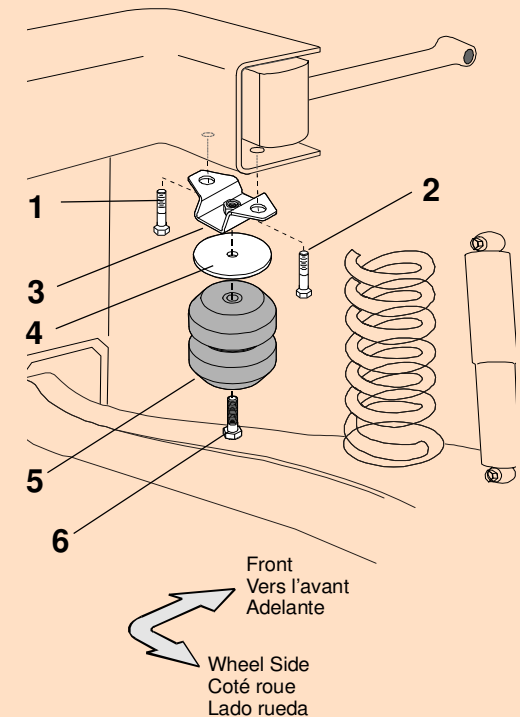

FRFLX

TIMBREN

# TIMBREN SES

## Suspension Enhancement Systems

### Clearance Instructions

#### For Light Duty Pickups & Vans

Rear SES kits should have approximately 1" gap between rubber spring and axle for 1/2 and 3/4 tons, and for one ton the gap should be about 1/2" when the vehicle is completely unloaded. A cap or fifth wheel plate will reduce or eliminate this gap.

Front SES kits are usually in contact with the front suspension

#### For Medium Duty & Heavy Duty Trucks, Trailers, Motor Homes, and more

Medium & Heavy Duty vehicles often have pre-load as outlined in the instruction sheet. (For specific Medium Duty applications with a constant load on the suspension like Rvs, Utility Vans or Cube Vans, the Timbren SES kits are pre-loaded.)

**Check clearances when vehicle is empty...**

### Consider Your Needs..!

Knowing the use of the vehicle will help you to select the right SES kit. For example a one ton truck can be configured as a pick-up, service vehicle or tow truck. Standard capacity or severe service applications are available for many applications.

Knowing that the suspension has been modified or is old and sagging should indicate the need to adjust the ride height to obtain the correct clearance.

This can be done by altering the SES kit (changing rubber spring or bracket) or re-arching the leaf springs to renew the optimum OEM ride height.



Ride Quality Control

Check clearance when Vehicle is Empty

Typical Light Duty Installation

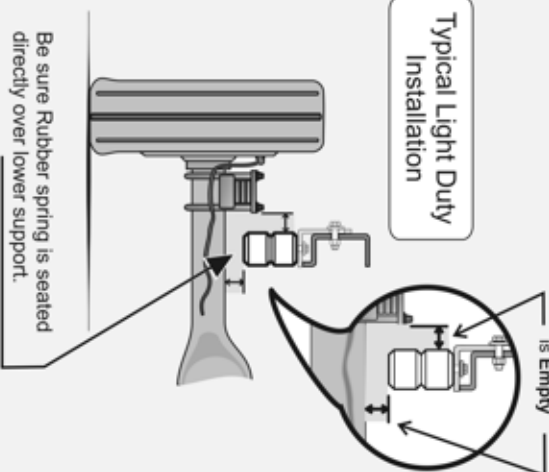

Typical Medium & Heavy Duty Installation

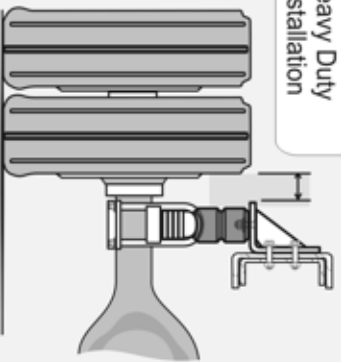

Timbren Industries Inc. ©

### Lifetime Warranty

TIMBREN SES kits are warranted against defects in material and workmanship, under normal use and service, for the life of the vehicle on which the kit was originally installed. The warranty is not transferable and proof of purchase is required. The warranty is limited to the replacement of the failed part. TIMBREN will not be responsible for any labour or freight charges involved in the replacement of any product. TIMBREN shall be entitled to make its own inspection to determine the validity of the warranty claim. TIMBREN shall not be liable nor warrant the product in the event of alteration, misuse, overload, negligence or

If ride or performance of our product is unsatisfactory in any way, please call:

**TIMBREN INDUSTRIES INC.**

**1-800-263-3113**



www.timbren.com

email: sales@timbren.com